



EXHIBITOR MANUAL

April 11-13, 2025

North Carolina State Fairgrounds



Enclosed you will find helpful information to make your participation in our show successful.

Please share this manual with those responsible for your participation in the show.



SHOW MANAGEMENT

The Southern Ideal Home Show is produced and managed by:

Marketplace Events
2000 Auburn Drive Suite 200
Beachwood, OH 44122

Erin Calabritto, Show Manager
P: 919-674-0409
E: erinc@mpeshows.com
www.marketplaceevents.com

SHOW FACILITY

The Southern Ideal Home Show is held at the North Carolina State Fairgrounds in the Exposition Center and the Jim Graham Building. **The show office is located in the Jim Graham building during all days of move-in, show, and move-out.**

North Carolina State Fairgrounds
Exposition Center & Jim Graham Building
4285 Trinity Rd
Raleigh, NC 27607
ncstatefair.org

UTILITIES

Electricity, Telephone, Water, etc.
These services are provided by the North Carolina State Fairgrounds.

Electrical: Standard electrical service is included with your booth space; please request a connection ahead of time if power is needed by emailing Erin Calabritto, Show Manager, at erinc@mpeshows.com at least one week prior to move-in. This connection is suitable for most everyday needs: phone chargers, laptops, lamps and lights, etc. If you need “advanced electrical connections” for things such as hot tubs, food trucks, massage chairs, or extensive lighting, it may also be arranged ahead of time by contacting Erin Calabritto at the email address above (there is a service charge which must be prepaid).

You may also request power on-site in the Show Office, located in the Jim Graham Building; however, last minute requests may experience a wait time for connection.

Water/Drainage: For water, please notify the Show Office on-site, located in the Jim Graham Building, when you are ready for water or drainage.

Internet: Wifi is available for exhibitors but requires a password which periodically changes—see the home page of the Exhibitor Kit section of the website for the current password or ask the Show Office staff in the Jim Graham Building on-site. It is suitable for most everyday connections: email, social media, etc. For streaming, hard line/high speed internet is advised. If you need hard line/high speed internet, you must email erinc@mpeshows.com at least 10 days prior to the show to arrange access. On-site orders for hard line/high speed internet will no longer be accepted in the show office during move-in.

MOVE-IN | MOVE-OUT DAYS AND HOURS

All accounts must be paid in full before you can move in. For safety reasons, no one under the age of 16 is permitted in the halls or dock areas during move-in/out. Carts and dollies are not available on-site, but feel free to bring your own.

You may use your own carts, hand trucks, dollies, etc.



Breaking down prior to show close at 6:00pm on Sunday is strictly prohibited.

Move-In Dates/Time

Tuesday	April 8, 2025	1:00pm-5pm Scheduled move-in ONLY for exhibits over 400 sq. ft.
Wednesday	April 9, 2025	8:00am - 5:00pm General Move-In
Thursday	April 10, 2025	8:00am - 5:00pm General Move-In

You must be completely set up by the end of the day on Thursday; there is no move-in permitted on Friday morning.

Move-Out Dates/Time

Sunday	April 13, 2025	6:01pm - 10:00pm
Monday	April 14, 2025	8:00am – NOON

All exhibit halls must be cleared by NOON on Monday.

SHOW HOURS

Friday	April 11, 2025	10:00am - 8:00pm
Saturday	April 12, 2025	10:00am - 8:00pm
Sunday	April 13, 2025	11:00am - 6:00pm

Exhibitors may enter the show two hours before opening on Friday and one hour before opening on Saturday and Sunday.

EXHIBITOR BADGES

Exhibitor badges are NOT mailed out prior to the show. Badges can be picked up in the Show Office (Jim Graham Building) during move-in and during show hours. Plastic badge holders are provided.

Exhibitor badges are required to identify you as an authorized exhibitor. Exhibitors will not be allowed access to the show floor on show days without a badge.

Six (6) exhibitor badges are provided for each 100 square feet of space purchased, with a maximum allotment of 24 badges per company.

If you have different staff members working your booth on different days, you are encouraged to drop off your badge each night in the Show Office, so that your company does not run out of badges during the show.

Exhibitor badges must not be used as admission tickets for guests and cannot be left at will call.

SHOW OFFICE

During move-in, show hours and move-out, Show Management will maintain a show office in Jim Graham Building of the North Carolina State Fairgrounds. The office is to the right, at the end of the hallway as you enter from the breezeway that connects the Exposition Center to the Jim Graham Building. Look for the show office sign.

EXHIBITOR ENTRANCES DURING SHOW HOURS

During show hours, exhibitors may use the main entrances to the Exposition Center and the Jim Graham Building. An exhibitor badge will be required to enter the show floor.

You will not be allowed to bring in exhibit supplies through the main entrance during show hours. Please visit the show office to make arrangements as needed for bringing in supplies during the show.

COMPLIMENTARY TICKETS

Each exhibitor will receive online ticket redemption codes valid for up to 40 show tickets. These will be emailed out three weeks prior to the show. Tickets will only be emailed out if your account has been settled in full. Pass your unique code along to your customers, who can go online and use it as a coupon code to redeem free tickets to the show using our eTicketing system. If you do not receive your tickets or you would like to request more, contact erinc@mpeshows.com.

COMPLIMENTARY TICKETS ARE NOT PERMITTED TO BE DISTRIBUTED AT THE ENTRANCE TO THE SHOW. Use your tickets to invite potential customers to the show, as a thank you to good customers or for friends and family.

WILL CALL

Will Call will be at the Box Office at the main entrance to the show in the Exposition Center. Tickets for your guests can be left at Will Call, providing that they are in an envelope with their first and last name on it, and how many tickets you have put inside. These will be filed by last name at Will Call, so please inform your invited guests to

ensure they are able to get into the show with ease! Please use your tickets for guests—exhibitor badges should not be left at Will Call for attendees.

DECORATOR SERVICES

Southern Exhibition Services (SES) is the show decorator and provides carpet, tables, chairs, cleaning, signage, etc. Please order these items directly from them. The forms are available on the Exhibitor Kit section of our website; look for the Decorator Manual link. They maintain an office at the show located in the Jim Graham Building, just outside the entrance to our Show Office.

PARKING

Exhibitor parking at the fairgrounds is free and unlimited. Trailers and box trucks may be parked down the hill from the Jim Graham Building in the dirt/gravel lot during move-in, the show, and move-out. These vehicles must be clear by Monday at 3pm when move-out concludes.

FOOD AND BEVERAGE SAMPLING

Bulk food or beverage sales can be considered for Fair Administration approval provided that any exhibitor offering food products must be pre-approved and adhere to the following guidelines. Exhibitors are required to provide a copy of their Certificate of Insurance to Erin Calabritto along with the request for sampling at least one month prior to show opening for approval.

Food products which are approved to be sold at an event must be packaged in bulk form and sealed for off-premises consumption. To avoid any confusion and consistently enforce terms of contractual agreements, a list of exhibitors selling food or beverage in bulk form along with a description of the proposed sample will be submitted to the Fairgrounds at least one month prior to the event for review.

The following are sampling guidelines applicable for approved exhibitor samples within State Fairgrounds facilities which have a food and beverage concessions contract:

- Sample being offered must be a product being offered by the exhibitor.
- Sample size - Beverage - sample amount 2 oz. or less
- Sample size - Food – sample should be 1 square inch or less and fit in a standard 1 inch condiment cup.
- Approved sampling must be offered in compliance with any regulatory requirements from Wake Environmental Services (919) 856-7419.
- Any approved sample containing alcohol will be subject to the current State Fair Alcohol Policy.

Please contact Erin Calabritto at erinc@mpeshows.com at least one month prior to the show to apply for sampling consideration and provide your required COI.

PROMOTIONAL ITEMS

We encourage exhibitors to give out promotional items at the show to market to attendees; however, due to the venue's policies, the following are not permitted:

- Alcohol as a promotional item (ex. having a “happy hour” in your booth or giving out glasses of wine)
- Any food or beverage distribution as a promotional item (ex. branded water bottles, cookies, candy, etc)

- Stickers and helium balloons are discouraged as they create a problem for the facility to clean up and you may be charged a cleanup fee (ex. sticker removal or balloons being stuck in the ceiling)

Branded totes, pens, cups, etc are welcome! The best way to promote your services is to post show specials on your Exhibitor Listing on our website for attendees to see before, during, and after the show. Promotional items are not allowed to be distributed anywhere at the show except your booth; speak to your Exhibit Sales Consultant if you are interested in a front entrance sponsorship, stage sponsorship, or feature sponsorship for additional exposure!

VEHICLES IN EXHIBITS

If you plan on having a vehicle in your booth as part of your display, please contact Show Manager, Erin Calabritto, at erinc@mpeshows.com for approval and move-in instructions.

- Visqueen must be put down on the floor before the vehicle is driven into place.
- All vehicles must have a locking gas cap or gas cap sealed with tape and no more than 1/4 tank of gas in the vehicle.
- A set of keys must be left with Show Management for the duration of the show.
- All vehicle batteries must be disconnected and cables taped.

BOOTH INFORMATION, RULES & REGULATIONS

Exhibit booths will have an 8' draped back wall. On each side, a draped side rail will extend from the back of the booth to the front of the booth at a height of 32". The drape color is black. **Tables, chairs, electricity etc. are not included with the cost of your exhibit booth.**

Flooring

Flooring is not included in the cost of your exhibit booth. **It is mandatory that all booths are carpeted** or have some type of clean, professional-looking floor covering that covers 100% of the booth's square footage.

Table Skirting

It is mandatory that all tables are properly skirted. Skirting must go from the edge of the table to the floor on all four sides. All skirting must be pressed and neat. Use of plastic table cloths, sheets, shower curtains or any type of "makeshift" table cloths is **not permitted**. We strictly enforce this and will skirt all incorrectly skirted tables at the exhibitor's expense. This requirement applies to all tables that are not furniture quality (meaning folding or temporary tables); finished furniture (of such quality that you would display in your home or office do not require skirting. Show management has final discretion if there is a question of whether a table should be skirted or not.

All inventory and personal items must be stored COMPLETELY OUT OF SIGHT. Your booth should look professional and inviting to the attendee.

(Continued next page)

Staffing Your Booth

All exhibitors are expected to be in their booths during all published show hours, as we do receive consumer complaints about un-manned displays. **Our visitors pay an entrance fee and expect to be able to do business with our exhibitors at any time during show hours. If you are in violation of this rule, your company may not be permitted to exhibit with us in the future.**

Working in the aisles or distributing brochures, etc. from any other area other than your booth is prohibited, including the aisles. All activity must take place inside your contracted space.

TENTS & HELIUM BALLOONS ARE NOT ALLOWED

Booth Guidelines

Exhibitors are allowed to build their booth to the maximum height of 8 feet. This includes back wall, sidewalls, and any marketing items in your booth (ex. signs, displays, flags, etc). 8' black drape is provided at the back of each inline booth, with 3' drape dividers provided in between inline booths.

If your display includes a sign attached to the back wall, **you must get approval from show management** and the following rules apply:

- Total height must not exceed 2' from the top of the 8' drape line
- Sign must be single sided and no designs or logos may face a neighboring booth
- Professionally finished and neat looking so as not to distract from a neighbor's booth design, or contain logos, exposed wiring, framing, raw wood, or otherwise unfinished material.
- No PVC pipe allowed
- Side walls must be completely finished on BOTH sides. No logos, exposed wires, frames, wood must be exposed for the public or your neighbor to see.
- Exceptions apply to island booths, end caps, and perimeter booths at the discretion of show management as they do not infringe upon neighboring booths.
- Teardrop flags and pop-up signs or other types of displays or signage may not extend to a height above 8' and may not extend into your neighbor's booth or out into the aisle.
- Show management has final approval on all signage.

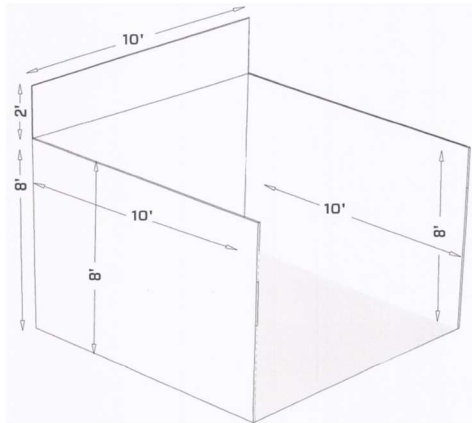

SECURITY

Security is provided and guards will be on duty throughout the event. Every reasonable precaution will be taken to protect exhibitors' property, but Show Management assumes no responsibility for any losses due to fire, theft, robbery, damage, accident or other causes.

INSURANCE

Show Management is insured against public liability and property damage claims arising out of the conduct of the show. This insurance does not cover exhibitors' property, which is placed on display at the exhibitor's risk. Please refer to your exhibitor contract or contact Show Management if you have questions. Every exhibitor is required to furnish proof of liability insurance; please list both of the following on your Certificate of Insurance and submit to your Exhibit Sales Representative prior to the first date of move-in. Insurance must be valid through all event dates including move-out.

Additional Insured:

Marketplace Events/Southern Ideal Home Show

NC State Fairgrounds

4285 Trinity Rd

Raleigh, NC 27607

HOT TUBS & SPAS

All hot tub/spa exhibitors must apply for a Wake County "Display Spa at Temporary Event" permit at least 15 calendar days prior to the event (see link on Exhibitor Kit to permit application and deadline). An on-site inspection must be arranged, and exhibitor must comply with current regulations, signage requirements, etc. as set forth by Wake County to display hot tubs/spas at the event.

Please submit the completed application(s) as a PDF to the following email address: wcpools@wake.gov. For more information, please call Wake County Environmental Services at 919-856-7400.

SHIPPING INFORMATION

Southern Exhibition Services (SES) charges a drayage fee for handling any materials delivered to the North Carolina State Fairgrounds home show expo buildings. Deliveries without company name and booth number will be declined. Contact Southern Exhibition Services if you are sending shipments ahead of your arrival. Marketplace Events and the North Carolina State Fairgrounds are not authorized to accept your shipment. Detailed shipment information can be found in the Decorator Manual, under the Exhibitor Kit section of our website.

THANK YOU

We thank you for exhibiting in the show and are here to help you have a great experience! Please let us know how we can be of service to you. For questions on move-in, move-out, or booth guidelines before or after the show, please contact your Exhibit Sales Consultant or Erin Calabritto, Show Manager at erinc@mpeshows.com or call/text (386) 334-1713 during business hours and show hours.