

JACKSONVILLE  
**HOME  
+ PATIO  
SHOW**

# EXHIBITOR MANUAL

September 27-29, 2024  
Prime Osborn Convention Center



Enclosed you will find helpful information to make your participation in our show successful.

Please share this manual with those responsible for your participation in the show.

**JacksonvilleHomeShows.com**

**MARKETPLACE | EVENTS**  
Largest Home Show Producer | in North America

## SHOW MANAGEMENT

The Jacksonville Home + Patio Home Show is produced and managed by:

### Marketplace Events

2000 Auburn Drive, Suite 200

Beachwood, OH 44122

[www.marketplaceevents.com](http://www.marketplaceevents.com)

Tina Robinson, Group Manager

[tinar@mpeshows.com](mailto:tinar@mpeshows.com)

---

## SHOW FACILITY

### The Prime Osborn Convention Center

1000 Water Street | Jacksonville, FL 32204

P: 904-630-4800

[www.JaxEvents.com](http://www.JaxEvents.com)

Aryana Burkett, Event Coordinator

[ABurkett@asmjax.com](mailto:ABurkett@asmjax.com)

---

## SHOW DECORATOR SERVICES

Veal Convention Services is the show decorator and provides carpet, tables, chairs, cleaning, signage, forklift service, etc. Please order these items directly from them. The forms are available on our website [www.JacksonvilleHomeShows.com](http://www.JacksonvilleHomeShows.com) under “Exhibitor Kit” at the bottom of the home page. **ORDER PRIOR TO SHOW WEEK TO GUARANTEE ORDERS. Use Veal’s Online Portal, this can be found on the online Exhibitor Kit. All orders are due by Friday before show opening.**

### Veal Convention Services

P: 205-328-1010 | [orders@vealco.com](mailto:orders@vealco.com)

[veal.boomerecommerce.com](http://veal.boomerecommerce.com)

---

## SHOW OFFICE

During move-in, show hours & move-out, Show Management will maintain an office in the Convention Center. The office is located in meeting room 106 downstairs. Look for the show office sign.

---

## SOCIAL MEDIA

Follow & tag the Jacksonville Home + Patio Show on social media before and during the show!

Include [#JaxHomeAndPatioShow](#) and [#JacksonvilleHomePatioShow](#) on your posts.

Tag us on Facebook [@JacksonvilleHomeShow](#) and on Instagram [@JacksonvilleHomeShows](#).

---

# MOVE-IN | MOVE-OUT DAYS AND HOURS

## ALL ACCOUNTS MUST BE PAID IN FULL BEFORE YOU MOVE-IN.

For safety reasons, no one under the age of 16 is permitted in the halls or dock areas during move-in/out.

### Move-In:

Tuesday	September 24, 2024	1:00pm-5:00pm*(400 sq ft and larger)
Wednesday	September 25, 2024	8:00am-5:00pm
Thursday	September 26, 2024	8:00am-5:00pm <b>*Drive-In Access Ends at 2 PM Thursday*</b>

Dock doors will close at 5pm on each day of move-in. Exhibitors can enter through the security entrance (Door 1) until 7pm. **Move-in must be completed by Thursday at 5pm.**

**Drive on access is prohibited in Sections 1-5 per the Prime Osborn Convention Center. No motorized vehicles are permitted in those areas.**

Exhibitors must use Door 1, Door 6, and Door 7 to access the show floor during move in. Please do not use any other doors. Propping doors open is strictly prohibited. Forklifts are available to assist with move-in. Check in with Show Decorator to arrange forklift/cart service.

### Move-Out:

Sunday	September 29, 2024	6:01pm – 10:00pm
Monday	September 30, 2024	8:00am – <b>NOON SHARP*</b>

**At 6:01pm on Sunday, aisle carpet must be rolled up before any carts or vehicles can be used in the building. Stay off the aisle carpet (including items you are dismantling and packing from your booth); it will make things go a lot faster for everyone.**

**\*All exhibit material must be out of the convention center by 12pm (Noon) on Monday.** Your space must be clean of all debris. If any materials are left behind, your company will be subject to a removal and cleaning fee. Marketplace Events is not responsible for any materials that are left in the building. **All pavers and pallets must be removed from parking lot by Monday at 12pm. No exceptions.** Materials not removed by this time are subject to handling fines. You may use your own carts, hand trucks, dollies, etc. **Dismantling your booth prior to show close at 6:00pm on Sunday is strictly prohibited.** This is a serious safety issue for our attendees and extremely discourteous to your neighboring exhibitors who are trying to conduct business. Do not break down early.

---

## SHOW HOURS

Friday	September 27, 2024	10:00am – 8:00pm
Saturday	September 28, 2024	10:00am – 8:00pm
Sunday	September 29, 2024	10:00am – 6:00pm

Exhibitors may enter the show one hour before opening through the Exhibitor Entrance.

## EXHIBITOR BADGES

Exhibitor badges are required to identify you as an authorized exhibitor. Exhibitors will not be allowed access to the show floor during show days without a badge.

Exhibitor badges are NOT mailed out prior to the show. Badges can be picked up in the Show Office Room 106 during move-in & during the show. Plastic badge holders are provided.

Six (6) exhibitor badges are provided for each 100 square feet of space purchased, with a maximum allotment of 24 badges per company. If you have different staff members working your booth on different days, you are encouraged to drop off your badge each night at the exhibitor check-in desk so that your company does not run out of badges during the show.

**Exhibitor badges must not be used as admission tickets and cannot be left at Will Call.**

---

## EXHIBITOR ENTRANCES DURING SHOW HOURS

During show hours, exhibitors may use Door #7 which is adjacent to the parking lot on the side of the building or the Exhibitor Entrance which is located across the courtyard to the left of the main entrance. Follow the signs to this entrance and/or refer to the show floor plan. An exhibitor badge will be required to enter the show floor. **Prime Osborn Convention Center Security requires bag check to enter the building during show days.**

The main entrance is for attendees and gets very crowded prior to opening each morning. You will not be allowed to bring in exhibit supplies through this entrance, including hand-carried items.

---

## COMPLIMENTARY TICKETS

Each exhibitor will receive online ticket redemption codes valid for 40 complimentary tickets to the show. These will be emailed out three weeks prior to the show. Tickets will only be emailed out if your account has been settled in full. Pass your unique code along to your customers, who can go online and use it as a coupon code to redeem free tickets to the show using our eTicketing system. If you do not receive your tickets or you would like to request more, contact [AshleyM@MPEshows.com](mailto:AshleyM@MPEshows.com).

If you wish to leave tickets at Will Call, you may redeem and print tickets using your unique code. See Will Call section below for how to leave them for your guests at the show.

**Complimentary tickets are not permitted to be distributed at the entrance of the show.** Use your tickets to invite potential customers to the show, as a thank you to good customers or for friends and family.

---

## WILL CALL

Will Call will be set up at the main entrance of the show in the box office. Please leave your tickets in INDIVIDUALLY marked envelopes with FIRST AND LAST NAME on the front of the envelope at Will Call for your guests. Exhibitor Badges are not to be left at Will Call; they can be left at the Show Office in Room 206 for your staff working your booth only (not as tickets to the show for attendees).

---

# EXHIBITOR FOOD & FOOD TRUCKS

The Prime Osborn Convention Center instituted thorough bag checks a few years ago. While looking for weapons is their primary objective, if security finds any outside food & beverage, it will be confiscated. **The Prime Osborn Convention Center does not allow ANY outside food and beverage.** This includes coffee and water.

Concession stands are open throughout the show and **there will be several food trucks onsite on Friday and Sunday. Let your staff know they can visit the courtyard on those dates to enjoy local eats.** Food truck information and menus are available on our website [www.JacksonvilleHomeShows.com](http://www.JacksonvilleHomeShows.com) under Features.

Marketplace Events has worked with the building to allow individuals with food allergies to be exempt from not being able to bring his/her own food. If this applies to you or your staff, **please reach out to our show team to be put on the food allergy exempt list by Friday, September 20, 2024.** Lists will be provided to security, ONLY those names on the list will be exempt. The building will NOT accept additions to the list once we are onsite.

Please be sure to reach out to any staff working your booth to make them aware of the venue's procedures.

---

## FOOD AND BEVERAGE SAMPLING

All food sampling must be approved by Savor Jacksonville. Beverage sampling is limited to 4oz and food samples are limited to 2oz. A written description that outlines the product and portion size to be sampled shall be submitted in advance to [Savor Jacksonville](http://Savor Jacksonville). These updated forms can be found on our website [www.JacksonvilleHomeShows.com](http://www.JacksonvilleHomeShows.com) – click on "Exhibitor Kit" at the bottom of the homepage. Some items require a buyout fee be paid to Savor Jacksonville. Please reach out to your sales rep and Savor Jacksonville with any questions.

---

## PROMOTIONAL ITEMS

We encourage exhibitors to give out promotional items at the show to market to attendees; however, due to the venue's policies, the following are not permitted:

- Alcohol as a promotional item (ex. having a "happy hour" in your booth or giving out glasses of wine)
- Any food or beverage distribution as a promotional item (ex. branded water bottles, cookies, candy, etc)
- Stickers and helium balloons are discouraged as they create a problem for the facility to clean up and you may be charged a cleanup fee (ex. sticker removal or balloons being stuck in the ceiling)

Branded totes, pens, cups, etc are welcome! The best way to promote your services is to post show specials on your Exhibitor Listing on our website for attendees to see before, during, and after the show. Promotional items are not allowed to be distributed anywhere at the show except your booth; speak to your Exhibit Sales Consultant if you are interested in a front entrance sponsorship, stage sponsorship, or feature sponsorship for additional exposure!

---

# UTILITIES AND SERVICES POLICY

Electricity, Telephone, Water, etc. are services are provided by the Prime Osborn Convention Center. Current rate sheets for labor, equipment rental and services are available on request. For safety reasons, Prime Osborn Convention Center personnel must perform installation of all utility services.

Please submit all service order forms with full payment enclosed to the Prime Osborn Convention Center. They cannot provide the service until payment is received.

See Exhibitor Kit for links to current forms, contact information, and ordering deadlines.

---

## VEHICLES IN EXHIBITS

If you plan on having a vehicle in your booth as part of your display, please contact Show Management for approval and move-in instructions.

- Visqueen must be put down on the floor before the vehicle is driven into place.
  - All vehicles must have a locking gas cap or gas cap sealed with tape and no more than 1/4 tank of gas in the vehicle.
  - A set of keys must be left with Show Management for the duration of the show.
  - All vehicle batteries must be disconnected and cables taped.
- 

## BOOTH INFORMATION, RULES & REGULATIONS

Exhibit booths will have an 8' draped back wall. On each side, a draped side rail will extend from the back of the booth to the front of the booth at a height of 32". The drape color is black. Tables, chairs, electricity etc. are not included with the cost of your exhibit booth.

**\*\*\*TENTS/CANOPIES ARE NOT PERMITTED\*\*\***

**\*\*\*HELIUM BALLOONS ARE PROHIBITED\*\*\***

### Flooring

Flooring is not included in the cost of your exhibit booth. Carpet tape must be approved and be easily removable – **NO DUCT TAPE ALLOWED**. The show decorator will provide approved carpet tape upon request. All pavers and hard surface flooring must be placed on top of visqueen over carpet. **It is mandatory that all exhibit booths are carpeted** or have some type of clean, professional-looking floor covering that covers 100% of the booth's square footage. All pavers and hard surface flooring must be placed on top of visqueen.

### Table Skirting

It is mandatory that all tables are properly skirted. Skirting must go from the edge of the table to the floor on all four sides. All skirting must be pressed and neat. Use of plastic table cloths, sheets, shower curtains or any type of "makeshift" table cloths is not permitted. We strictly enforce this and will skirt all incorrectly skirted tables at the exhibitor's expense.

All inventory and personal items must be stored completely out of sight. Your booth should look professional and inviting to the attendee.

## **Staffing Your Booth**

All exhibitors are expected to be in their booths during all published show hours, as we do receive consumer complaints about un-manned displays. Our visitors pay an entrance fee and expect to be able to do business with our exhibitors at any time during show hours. If you are in violation of this rule, your company may not be permitted to exhibit with us in the future. **Working in the aisles or distributing brochures, etc. from any other area other than your booth is prohibited. All activity must take place inside your contracted space.**

## **Booth Guidelines**

Exhibitors are allowed to build their booth to the maximum height of 8 feet. This includes back wall and sidewalls. If your display includes a sign attached to the back wall, you must get approval from show management and the following rules apply:

- Total height of sign must not exceed two feet from top of drape line
- Sign must be single-sided
- Professionally finished (no raw plywood, exposed wiring, etc may be showing from any side as a courtesy to your neighboring booths)
- No PVC pipe allowed
- No marketing materials (teardrop flags, banners, etc.) above 10' are permitted. Air rights may be purchased depending on booth size; contact your sales consultant for review, approval, and applicable fees. Please contact your sales consultant for the deadline for your high sign to be on site for rigging if you've purchased air rights.

If you are using side walls as part of your display they must be completely finished on BOTH sides. No exposed wires, frames, wood must be exposed for the public or your neighbor to see.

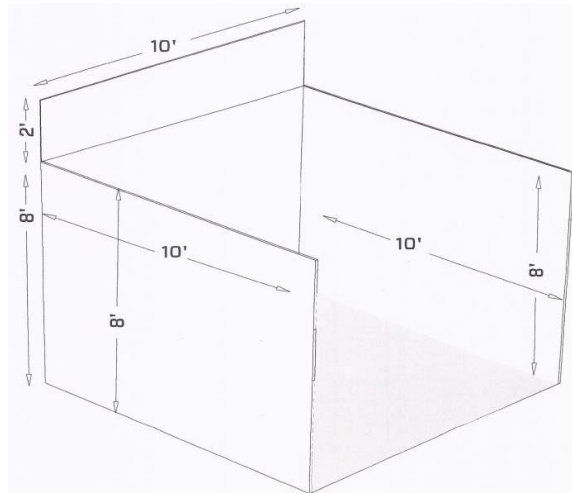

---

## **SECURITY**

Security is provided by the Prime Osborn Convention Center and guards will be on duty 24 hours throughout the event. Every reasonable precaution will be taken to protect exhibitors' property, but Show Management assumes no responsibility for any losses due to fire, theft, robbery, damage, accident or other causes.

## INSURANCE

Show Management is insured against public liability and property damage claims arising out of the conduct of the show. This insurance does not cover exhibitors' property, which is placed on display at the exhibitor's risk. Please refer to items #4 and 5 on your exhibitor contract/application or contact Show Management if you have questions.

---

## SHIPPING INFORMATION

Veal Convention Services charges a drayage fee for handling any materials delivered to the convention center. Deliveries without company name and booth number will be declined. **Contact Veal Convention Services if you are sending shipments ahead of your arrival.** Marketplace Events and Prime Osborn Convention Center are not authorized to accept your shipment.

### Delivery address:

Veal Convention Services  
c/o Prime Osborn Convention Center  
1000 Water Street  
Jacksonville, FL 32204

**Company name and booth number.**

**\*ALL DELIVERIES COMING TO THE PRIME OSBORN CONVENTION CENTER FOR YOUR COMPANY MUST BE PICKED UP THE SAME DAY AS DELIVERED!\***

For more information about shipping to & from the show, please contact Veal Convention Services at 1-800-844- 8325.

---

## PARKING

Exhibitor parking is located in the North Parking Lot 1 during show days (grass lot). An exhibitor badge and purchased parking pass is required for entry into the lot. Parking passes can be purchased in advance & during move-in.

**All exhibitor vehicles (unless you have a Disabled Permit or on file with MPE) must be moved from front of the West Lost by 9am on show days or risk towing.** See map below.

---



