



EXHIBITOR MANUAL

February 28 – March 2, 2025
Prime Osborn Convention Center



Enclosed you will find helpful information to make your participation in our show successful.

Please share this manual with those responsible for your participation in the show.

JacksonvilleHomeShows.com

MARKETPLACE | EVENTS
Largest Home Show Producer in North America

SHOW MANAGEMENT

The Jacksonville Home + Patio Home Show is produced and managed by:

Marketplace Events

2000 Auburn Drive, Suite 200

Beachwood, OH 44122

www.marketplaceevents.com

SHOW TEAM

Tina Robinson	Group Manager	tinar@mpeshows.com	904-622-9140
Taylor Treadway-Burgess	Sales Manager #-F, P-Z	taylor@mpeshows.com	904-420-3105
Brooklyn Paczkowski	Exhibit Sales Consultant G-O	brooklynp@mpeshows.com	904-380-7956
Rachel Whitmire	Operations Manager	rachelw@mpeshows.com	904-594-1253

SHOW FACILITY

The Prime Osborn Convention Center

1000 Water Street | Jacksonville, FL 32204

P: 904-630-4800

www.JaxEvents.com

Aryana Burkett, Event Coordinator

ABurkett@asmjax.com

SHOW DECORATOR SERVICES

Booth Furnishings: rental of tables, chairs, booth carpeting, signs, & labor

RPMxpo

242 Westfork Court, Suite A

Lithia Springs, Georgia 30122

P: (678)742-7310

F: 770-679-8751

info@rpmxpo.com

SHOW OFFICE

During move-in, show hours & move-out, Show Management will maintain an office in the Convention Center. The office is located in meeting room 106 downstairs. Look for the show office sign.

SOCIAL MEDIA

Follow & tag the Jacksonville Home + Patio Show on social media before and during the show!

Include [#JaxHomeAndPatioShow](https://twitter.com/#JaxHomeAndPatioShow) and [#JacksonvilleHomePatioShow](https://twitter.com/#JacksonvilleHomePatioShow) on your posts.

Tag us on Facebook [@JacksonvilleHomeShow](https://www.facebook.com/JacksonvilleHomeShow) and on Instagram [@JacksonvilleHomeShows](https://www.instagram.com/JacksonvilleHomeShows).

MOVE-IN | MOVE-OUT DAYS AND HOURS

ALL ACCOUNTS MUST BE PAID IN FULL BEFORE YOU MOVE-IN.

For safety and liability reasons, no one under the age of 16 is permitted in the halls or dock areas during move-in/out.

MOVE-IN DAYS AND HOURS

Tuesday	February 25, 2025	1:00pm – 5:00pm (400 sq ft and larger)
Wednesday	February 26, 2025	8:00am – 5:00pm
Thursday	February 27, 2025	8:00am – 5:00pm

Dock doors will close at 5pm on each day of move-in. Exhibitors can enter through the security entrance (Door 1) until 7pm. **Move-in must be completed by Thursday at 5pm.**

NEW - IMPORTANT CHANGE FOR 2024

The Prime Osborn Convention Center policies for the carpeted sections of the venue have changed. Effective immediately, drive on access is prohibited in Sections 1-5. No motorized vehicles are permitted in those areas.

Exhibitors must use Door 1, Door 6, and Door 7 to access the show floor during move in. Please do not use any other doors. Propping doors open is strictly prohibited. Forklifts are available to assist with move-in. Check in with Show Decorator to arrange forklift/cart service.

MOVE-OUT DAYS AND HOURS

Sunday	March 2, 2025	6:01pm – 10:00pm
Monday	March 3, 2025	8:00am – 12:00pm SHARP*

At 6:01pm on Sunday, aisle carpet must be rolled up before any carts or vehicles can be used in the building. Stay off the aisle carpet (including items you are dismantling and packing from your booth); it will make things go a lot faster for everyone.

***All exhibit material must be out of the convention center by 12pm (Noon) on Monday.** Your space must be clean of all debris. If any materials are left behind, your company will be subject to a removal and cleaning fee. Marketplace Events is not responsible for any materials that are left in the building. **All pavers and pallets must be removed from parking lot by Monday at 12pm. No exceptions.** Materials not removed by this time are subject to handling fines. You may use your own carts, hand trucks, dollies, etc. **Dismantling your booth prior to show close at 6:01pm on Sunday is strictly prohibited.** This is a serious safety issue for our attendees and extremely discourteous to your neighboring exhibitors who are trying to conduct business. Do not break down early.

SHOW HOURS

Friday	March 1, 2025	10:00am – 8:00pm
Saturday	March 2, 2025	10:00am – 8:00pm
Sunday	March 3, 2025	10:00am – 6:00pm

***You must man your booth each day from show open to show close. Leaving early is a violation of your signed contract.**

Exhibitors may enter the show one hour before opening through the Exhibitor Entrance.

EXHIBITOR BADGES

Exhibitor badges are required to identify you as an authorized exhibitor. Exhibitors will not be allowed access to the show floor during show days without a badge.

Exhibitor badges are NOT mailed out prior to the show. Badges can be picked up in the Show Office Room 106 during move-in & during the show. Plastic badge holders are provided.

Six (6) exhibitor badges are provided for each 100 square feet of space purchased, with a maximum allotment of 24 badges per company. If you have different staff members working your booth on different days, you are encouraged to drop off your badge each night at the exhibitor check-in desk so that your company does not run out of badges during the show.

Exhibitor badges must not be used as admission tickets and cannot be left at Will Call.

EXHIBITOR ENTRANCES DURING SHOW HOURS

During show hours, exhibitors may use Door #7 which is adjacent to the parking lot on the side of the building or the Exhibitor Entrance which is located across the courtyard to the left of the main entrance. Follow the signs to this entrance and/or refer to the show floor plan. An exhibitor badge will be required to enter the show floor. **Prime Osborn Convention Center Security requires bag check to enter the building during show days.**

The main entrance is for attendees and gets very crowded prior to opening each morning. You will not be allowed to bring in exhibit supplies through this entrance, including hand-carried items.

COMPLIMENTARY TICKETS

Each exhibitor will receive online ticket redemption codes valid for 40 complimentary tickets to the show. These will be emailed out three weeks prior to the show. Tickets will only be emailed out if your account has been settled in full. Pass your unique code along to your customers, who can go online and use it as a coupon code to redeem free tickets to the show using our eTicketing system. If you do not receive your tickets or you would like to request more, contact rachelw@mpeshows.com.

If you wish to leave tickets at Will Call, you may redeem and print tickets using your unique code. See Will Call section below for how to leave them for your guests at the show.

Complimentary tickets are not permitted to be distributed at the entrance of the show. Use your tickets to invite potential customers to the show, as a thank you to good customers or for friends and family.

WILL CALL

Will Call will be set up at the main entrance of the show in the box office. Please leave your tickets in INDIVIDUALLY marked envelopes with FIRST AND LAST NAME on the front of the envelope at Will Call for your guests. Exhibitor Badges are not to be left at Will Call; they can be left at the Show Office in Room 206 for your staff working your booth only (not as tickets to the show for attendees).

EXHIBITOR FOOD & FOOD TRUCKS

The Prime Osborn Convention Center instituted thorough bag checks a few years ago. While looking for weapons is their primary objective, if security finds any outside food & beverage, it will be confiscated. **The Prime Osborn Convention Center does not allow ANY outside food and beverage.** This includes coffee and water.

Concession stands are open throughout the show and **there will be two food trucks onsite on Friday and Sunday. Let your staff know they can visit the courtyard on those dates to enjoy local eats.** Food truck information and menus are available on our website www.JacksonvilleHomeShows.com under Features.

Marketplace Events has worked with the building to allow individuals with food allergies to be exempt from not being able to bring his/her own food. If this applies to you or your staff, **please reach out to our show team to be put on the food allergy exempt list by Friday, February 21, 2025.** Lists will be provided to security, ONLY those names on the list will be exempt. The building will NOT accept additions to the list once we are onsite.

Please be sure to reach out to any staff working your booth to make them aware of the venue's procedures.

FOOD AND BEVERAGE SAMPLING

All food sampling must be approved by Savor Jacksonville. Beverage sampling is limited to 4oz and food samples are limited to 2oz. A written description that outlines the product and portion size to be sampled shall be submitted in advance to Savor Jacksonville. These updated forms can be found on our website www.JacksonvilleHomeShows.com – click on "Exhibitor Kit" at the bottom of the homepage. Some items require a buyout fee be paid to Savor Jacksonville. Please reach out to your sales rep and Savor Jacksonville with any questions.

PROMOTIONAL ITEMS

We encourage exhibitors to give out promotional items at the show to market to attendees; however, due to the venue's policies, the following are not permitted:

- Alcohol as a promotional item (ex. having a "happy hour" in your booth or giving out glasses of wine)
- Any food or beverage distribution as a promotional item (ex. branded water bottles, cookies, candy, etc)
- Stickers are discouraged and helium balloons are NOT PERMITTED as they create a problem for the facility to clean up and you may be charged a cleanup fee (ex. sticker removal or balloons being stuck in the ceiling)

Branded totes, pens, cups, etc are welcome! The best way to promote your services is to post show specials on your Exhibitor Listing on our website for attendees to see before, during, and after the show. Promotional items are not allowed to be distributed anywhere at the show except your booth; speak to your Exhibit Sales Consultant if you are interested in a front entrance sponsorship, stage sponsorship, or feature sponsorship for additional exposure!

UTILITIES AND SERVICES POLICY

Electricity, Telephone, Water, etc. are services are provided by the Prime Osborn Convention Center. Current rate sheets for labor, equipment rental and services are available on request. For safety reasons, Prime Osborn Convention Center personnel must perform installation of all utility services.

Please submit all service order forms with full payment enclosed to the Prime Osborn Convention Center. They cannot provide the service until payment is received.

See online Exhibitor Kit for links to current forms, contact information, and ordering deadlines.

VEHICLES IN EXHIBITS

If you plan on having a vehicle in your booth as part of your display, please contact Show Management for approval and move-in instructions.

- Visqueen must be put down on the floor before the vehicle is driven into place.
- All vehicles must have a locking gas cap or gas cap sealed with tape and no more than 1/4 tank of gas in the vehicle.
- A set of keys must be left with Show Management for the duration of the show.
- All vehicle batteries must be disconnected and cables taped.

BOOTH INFORMATION, RULES & REGULATIONS

Exhibit booths will have an 8' draped back wall. Drape color is black. On each side, a draped side rail will extend from the back of the booth to the front of the booth at a height of 32". The drape color is black. Tables, chairs, electricity etc. are not included with the cost of your exhibit booth.

*****TENTS/CANOPIES ARE NOT PERMITTED*****

*****HELIUM BALLOONS ARE NOT PERMITTED*****

FLOORING

Flooring is not included in the cost of your exhibit booth. **It is mandatory that all exhibit booths located in Section 6 are carpeted** or have some type of clean, professional-looking floor covering that covers 100% of the booth's square footage. Carpeting, Astroturf, hardwood, paver, tile squares, vinyl flooring etc., may be used. Carpet tape must be approved and be easily removable – **NO DUCT TAPE ALLOWED**. The show decorator will provide approved carpet tape upon request. All pavers and hard surface flooring must be placed on top of visqueen. Do not drill holes, paint, nail glue or affix flooring to the Convention Center flooring. Any damage to the Center's flooring will be repaired at the exhibitor's expense. **Booths in sections 1-5 are located in a carpeted area of the building and do not require flooring.**

TABLE SKIRTING

It is mandatory that all tables are properly skirted. Skirting must go from the edge of the table to the floor on all four sides. All skirting must be pressed and neat. Use of plastic table cloths, sheets, shower curtains or any type of "makeshift" table cloths is not permitted. We strictly enforce this and will skirt all incorrectly skirted tables at the exhibitor's expense.



All inventory and personal items must be stored completely out of sight. Your booth should look professional and inviting to the attendee.

STAFFING YOUR BOOTH

All exhibitors are expected to be in their booths during all published show hours, as we do receive consumer complaints about un-manned displays. Our visitors pay an entrance fee and expect to be able to do business with our exhibitors at any time during show hours. If you are in violation of this rule, your company may not be permitted to exhibit with us in the future.

Working in the aisles or distributing brochures, etc. from any other area other than your booth is prohibited. All activity must take place inside your contracted space.

DEMONSTRATIONS AND HANDOUTS

Exhibitors demonstrating products and/or distributing marketing materials, product samples or souvenirs are not permitted to do outside the confines of their rented exhibit area. Working in the aisle is strictly prohibited and will be enforced by show management. This includes any mascots.

ALL FOOD SAMPLING MUST BE APPROVED BY SHOW MANAGEMENT, VENUE, & HEALTH DEPARTMENT BY COMPLETING FORMS AND PAYING MANDATORY FEES.

BOOTH GUIDELINES

Exhibitors are allowed to build their booth to the maximum height of 8 feet. This includes back wall and sidewalls. If your display includes a sign attached to the back wall, you must get approval from show management and the following rules apply:

- Total height of sign must not exceed two feet from top of drape line
- Sign must be single-sided
- Professionally finished (no raw plywood, exposed wiring, etc may be showing from any side as a courtesy to your neighboring booths)
- No PVC pipe allowed
- No marketing materials (teardrop flags, banners, etc.) above 10' are permitted. Air rights may be purchased depending on booth size; contact your sales consultant for review, approval, and applicable fees.

If you are using side walls as part of your display they must be completely finished on BOTH sides. No exposed wires, frames, wood must be exposed for the public or your neighbor to see.



Figure 8' high x 10' wide x 3' front to back sides

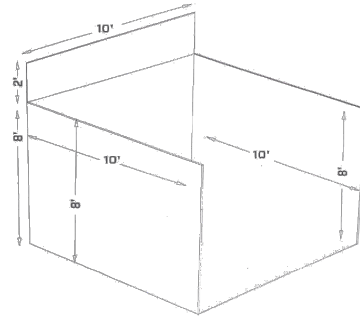

SECURITY

Security is provided by the Prime Osborn Convention Center and guards will be on duty 24 hours throughout the event. Every reasonable precaution will be taken to protect exhibitors' property, but Show Management assumes no responsibility for any losses due to fire, theft, robbery, damage, accident or other causes.

INSURANCE

Show Management is insured against public liability and property damage claims arising out of the conduct of the show. This insurance does not cover exhibitors' property, which is placed on display at the exhibitor's risk. Please refer to items #4 and 5 on your exhibitor contract/application or contact Show Management if you have questions.

SHIPPING INFORMATION

All shipments must go through RPMxpo, please contact them for pricing on handling shipments. Marketplace Events and Prime Osborn Convention Center are not authorized to accept your shipment.

Advance Shipment Address Must arrive by 2/14/25	Direct Shipment Address Cannot be delivered prior to 2/25/25
[Exhibiting Co. Name & Booth #] Jacksonville Home + Patio Show RPMxpo c/o ABF Freight 6900 Broadway Ave Jacksonville, FL 32254	c/o RPMxpo [Exhibiting Co. Name & Booth #] Jacksonville Home + Patio Show Prime Osborn Convention Center 1000 Water Street Jacksonville, FL 32204

ALL DELIVERIES COMING TO THE PRIME OSBORN CONVENTION CENTER FOR YOUR COMPANY MUST BE PICKED UP THE SAME DAY AS DELIVERED!

All shipments must be prepaid and should be clearly marked with your company name, booth number and Building Name. Special arrangements may be made with RPMxpo on items that need special care. Shipping items to the venue, may incur additional charges.

Show Management is not responsible for your packages; please do not send packages before your arrival as you **MUST** be present to sign for them.

Please make arrangements to dispose of or store shipping crates with the show decorator.

PARKING

Exhibitor parking is located in the North Parking Lot 1 during show days (grass lot). An exhibitor badge and purchased parking pass is required for entry into the lot. Parking passes can be purchased in advance & during move-in.

All exhibitor vehicles (unless handicap noted or on file with MPE) must be moved from front of the West Lost by 9am on show days or risk towing.

See map below.

