

January 24-26, 2025  
Gas South Convention Center



Enclosed you will find helpful information to make your participation in our show successful.

**Please share this manual with those responsible for your participation in the show.**

**NorthAtlantaHomeShow.com**

**MARKETPLACE | EVENTS**  
Largest Home Show Producer | in North America

# SHOW MANAGEMENT

The North Atlanta Home Show is produced and managed by:

## Marketplace Events

2000 Auburn Drive, Suite 200  
Beachwood, OH 44122  
[www.marketplaceevents.com](http://www.marketplaceevents.com)

---

## SHOW TEAM

Tina Robinson	Group Manager	<a href="mailto:tinar@mpeshows.com">tinar@mpeshows.com</a>	904-622-9140
Kim Huggins	Senior Exhibit Sales Consultant A-K	<a href="mailto:kimh@mpeshows.com">kimh@mpeshows.com</a>	770-776-2617
Kelsey Sablowski	Exhibit Sales Consultant L-Z	<a href="mailto:kelseys@mpeshows.com">kelseys@mpeshows.com</a>	770-776-2618
Rachel Whitmire	Operations Manager	<a href="mailto:rachelw@mpeshows.com">rachelw@mpeshows.com</a>	904-594-1253

---

## SHOW FACILITY

**Gas South Convention Center**  
6400 Sugarloaf Pkwy | Duluth, GA 30097  
P: 770.813.7500  
[www.GasSouthDistrict.com](http://www.GasSouthDistrict.com)

Megan Turner, Event Coordinator  
[mturner@gassouthdistrict.com](mailto:mturner@gassouthdistrict.com)

---

## SHOW DECORATOR SERVICES

Gilbert Exposition Management Services (GEMS) is the show decorator and provides carpet, tables, chairs, cleaning, signage, forklift service, etc. Please order these items directly from them using their [online ordering portal](#). You will receive a separate email containing your log in credentials from [orders@gemevents.com](mailto:orders@gemevents.com). If you have not received your login information, please be sure to check your junk/spam folder and if you still don't see it, please email [jill@gemsevents.com](mailto:jill@gemsevents.com) or [britney@gemsevents.com](mailto:britney@gemsevents.com) and they will resend it. **ORDER PRIOR TO SHOW WEEK TO GUARANTEE ORDERS. Use GEMS' Online Portal, this can be found on the online Exhibitor Kit. All orders are due by Friday before show opening. Exhibitor Discount end 1/6/25.**

### Gilbert Exposition Management Services (GEMS)

P: 407-438-5002 | [orders@gemevents.com](mailto:orders@gemevents.com) | [www.gemsevents.com](http://www.gemsevents.com)

---

## SHOW OFFICE

Our show office will open on Tuesday, January 21 at 8am. When you arrive to move-in, please check in and pick up your exhibitor badges and complimentary show tickets. The show office will remain open through the end of the show, on Sunday, January 28. The show office is in the Dogwood meeting room, in the lobby area, outside the Hall C entrance doors.

## SOCIAL MEDIA

Follow & tag the North Atlanta Home Show on social media before and during the show!  
Include #AtlantaHomeShow and #NorthAtlantaHomeShow on your posts.  
Tag us on Facebook [@AtlantaHomeShow](https://www.facebook.com/AtlantaHomeShow) and on [@AtlantaHomeShow](https://www.instagram.com/AtlantaHomeShow).

---

## MOVE-IN | MOVE-OUT DAYS AND HOURS

### ALL ACCOUNTS MUST BE PAID IN FULL BEFORE YOU MOVE-IN.

For safety and liability reasons, no one under the age of 16 is permitted in the halls or dock areas during move-in/out.

### MOVE-IN DAYS AND HOURS

Move begins on Tuesday January 21 and ends Thursday January 23.

Tuesday	January 21, 2025	12:00pm – 5:00pm*
Wednesday	January 22, 2025	8:00am – 7:00pm*
Thursday	January 23, 2025	8:00am – 8:00pm*

**\*Exact move-in times will be communicated to exhibitors approximately 3-4 weeks before the show. They are based on the size and location of the booth space. If you have any special requirements for the move-in of your booth, please communicate what they are ASAP to the show team.**

As a general rule, vehicles will not be allowed on to the show floor after some point on Wednesday afternoon. This is to allow the decorator to complete their booth set-up.

Exhibitors requiring forklift service should make arrangements with the Show Decorator prior to move in. Call GEMS at 407-438-5002 for verification of the rate for your particular need and any other questions.

If the back-loading dock is full, you will be directed to the marshaling area to stage until room becomes available. Please see the attached map for reference.

**Move-in must be completed by 8:00pm on Thursday, January 23, 2025.**

Make sure to clear all trash, boxes, crates, etc. from the aisles on Thursday, January 23, 2025.

**If you need additional time, please make special arrangements with Show Management.**

### MOVE-OUT DAYS AND HOURS

Sunday	January 26, 2025	5:01pm – 10.00pm
Monday	January 27, 2025	8:00am – 12:00pm**SHARP

**NO EXHIBIT CAN BE REMOVED, EVEN IN PART, UNTIL IT IS ANNOUNCED OVER THE PUBLIC ADDRESS SYSTEM THAT IT IS PERMISSIBLE, LISTEN FOR THE ANNOUNCEMENT - IT WILL BE LOUD AND CLEAR!**

**At 5:01pm on Sunday, aisle carpet must be rolled up before any carts or vehicles can be used in the building. Stay off the aisle carpet (including items you are dismantling and packing from your booth); it will make things go a lot faster for everyone.** After aisles are clear of carpet, vehicles may enter the building for loading of heavy items, **as long as there is a pathway for access.** If there is not a clear pathway, the exhibitor will have to wait until there is, or load via the docks and exit doors. It is unlikely that vehicles will be able to enter until later into the evening.

We strongly encourage you to move out on Sunday night, as Monday will see heavier traffic and more large vehicles needing facility access.

During Move-Out everything that your company brought to the Show must be removed or disposed of after the Show. If not, there will be a charge to your company for cleanup. **Any damage to the facility floor will be charged to your company.**

**\*\*All exhibit material must be out of the convention center by 12pm (Noon) on Monday.** Your space must be clean of all debris. If any materials are left behind, your company will be subject to a removal and cleaning fee. Marketplace Events is not responsible for any materials that are left in the building. **All pavers and pallets must be removed from parking lot by Monday at 12pm. No exceptions.** Materials not removed by this time are subject to handling fines. You may use your own carts, hand trucks, dollies, etc. **Dismantling your booth prior to show close at 5:01pm on Sunday is strictly prohibited.** This is a serious safety issue for our attendees and extremely discourteous to your neighboring exhibitors who are trying to conduct business. Do not break down early.

---

## SHOW HOURS

Friday	January 24, 2025	10:00am – 6:00pm
Saturday	January 25, 2025	10:00am – 7:00pm
Sunday	January 26, 2025	11:00am – 5:00pm

**\*You must man your booth each day from show open to show close. Leaving early is a violation of your signed contract.**

---

## ACCOUNT BALANCES

Final payment for exhibit space must be made by **December 31, 2024**. Show management reserves the right to refuse entry to any exhibitor whose account has not been paid in full. Exhibitor account balances must be made in full before you move-in. **Exhibitor Badges and complimentary tickets will not be available until the account has been paid in full.**

---

## EXHIBITOR BADGES

Exhibitor badges are required to identify yourself as an authorized exhibitor. Exhibitors will not be allowed access during show days without a badge. Exhibitor badges are not required during move-in.

Five (5) exhibitor badges are provided for 200 square feet of space or less.

Ten (10) exhibitor badges are provided for 201 square feet of space or more.

If you have a large staff, you are encouraged to drop off your badges each night in the Show Office, so that your company does not run out of badges.

**EXHIBITOR BADGES MAY NOT BE USED AS ADMISSION TICKETS AND CANNOT BE LEFT AT WILL CALL.**

---

## COMPLIMENTARY TICKETS

Each exhibitor will receive 5 complimentary tickets per 100 square feet.

If you need additional tickets, these can be purchased at half price for \$5 each prior to the show or at the show office any time during the show. **See the last page of this manual for the ticket order form.**

**COMPLIMENTARY TICKETS ARE NOT PERMITTED TO BE DISTRIBUTED AT THE ENTRANCE TO THE SHOW.** Use your tickets to invite potential customers to the show, as a thank you to good customers and for friends and family.

---

## WILL CALL

Will Call will be in the Show Office (just next to the show entrance in the Dogwood room) Please leave your tickets in INDIVIDUALLY marked envelopes with FIRST AND LAST NAME on the front of the envelope at Will Call for your guests.

**EXHIBITOR BADGES ARE FOR EXHIBITORS, THEY ARE NOT TICKETS TO THE SHOW. THEY SHOULD NOT BE LEFT AT WILL CALL TO BE PICKED UP BY ATTENDEES. THEY MAY ONLY BE LEFT FOR PEOPLE WORKING YOUR BOOTH.**

---

## PROMOTIONAL ITEMS

We encourage exhibitors to give out promotional items at the show to market to attendees; however, due to the venue's policies, the following are not permitted:

- Alcohol as a promotional item (ex. having a "happy hour" in your booth or giving out glasses of wine)
- Any food or beverage distribution as a promotional item (ex. branded water bottles, cookies, candy, etc)
- Stickers are discouraged and helium balloons are NOT PERMITTED as they create a problem for the facility to clean up and you may be charged a cleanup fee (ex. sticker removal or balloons being stuck in the ceiling)

Branded totes, pens, cups, etc are welcome! The best way to promote your services is to post show specials on your Exhibitor Listing on our website for attendees to see before, during, and after the show. Promotional items are not allowed to be distributed anywhere at the show except your booth; speak to your Exhibit Sales Consultant if you are interested in a front entrance sponsorship, stage sponsorship, or feature sponsorship for additional exposure!

---

## UTILITIES

### Telephone, Internet & Electricity

To place your electrical order for your booth, you can order directly online at:

[https://www.gassouthdistrict.com/order\\_forms/detail/service-order-form](https://www.gassouthdistrict.com/order_forms/detail/service-order-form)

To order additional utilities (i.e. water, etc.) or should you have any questions placing your order, please call or email Gas South District.

P: 770-813-7574 (Customer Service) | Email: [technicalservices@gassouthdistrict.com](mailto:technicalservices@gassouthdistrict.com)

**\*Please note, standard wi-fi is free\***

---

## VEHICLES IN EXHIBITS

If you plan on having a vehicle in your booth as part of your display, please contact Show Management for approval and move-in instructions. You must also complete a form for the Gas South Convention Center to have your vehicle on the show floor.

- All vehicles must have a locking gas cap or gas cap sealed with tape and no more than 1/4 tank of gas in the vehicle in accordance with the Atlanta State Fire Marshal.
- A set of keys must be left with Show Management for the duration of the show.
- All vehicle batteries must be disconnected, and cables taped.

## BOOTH INFORMATION, RULES & REGULATIONS

Exhibit booths will have an 8' draped back wall. Drape color is black. On each side, a draped side rail will extend from the back of the booth to the front of the booth at a height of 32". The drape color is black. Tables, chairs, electricity etc. are not included with the cost of your exhibit booth.

**\*\*\*TENTS/CANOPIES ARE NOT PERMITTED EXCEPT FOR ISLAND BOOTHS\*\*\***

**\*\*\* HELIUM, PROPANE OR GAS CONTAINERS ARE NOT PERMITTED\*\*\***

**\*\*\*HELIUM BALLOONS ARE NOT PERMITTED\*\*\***

### FLOORING

Flooring is not included in the cost of your exhibit booth. **It is mandatory that all exhibit booths are carpeted or have some type of clean, professional-looking floor covering that covers 100% of the booth's square footage.** Carpeting, Astroturf, hardwood, tile squares, vinyl flooring etc., may be used.

Carpet tape must be approved and be easily removable – **NO DUCT TAPE ALLOWED.** The show decorator will provide approved carpet tape upon request. All pavers and hard surface flooring must be placed on top of visqueen. Do not drill holes, paint, nail glue or affix flooring to the Convention Center flooring. **Any damage to the Center's flooring will be repaired at the exhibitor's expense.**

### TABLE SKIRTING

It is mandatory that all tables are properly skirted. Skirting must go from the edge of the table to the floor on

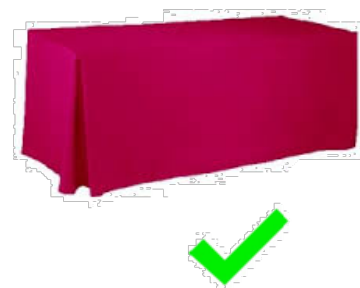
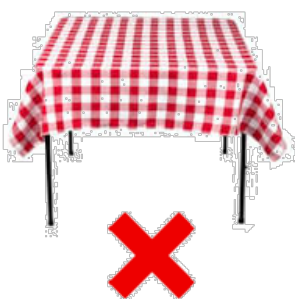

all four sides. All skirting must be pressed and neat. **Use of plastic table cloths, sheets, shower curtains or any type of "makeshift" table cloths is not permitted.** We strictly enforce this and will skirt all incorrectly skirted tables at the exhibitor's expense.

All inventory and personal items must be stored COMPLETELY OUT OF SIGHT. Your booth should look professional and inviting to the attendee.

### STAFFING YOUR BOOTH

All exhibitors are expected to be in their booths during all published show hours, as we do receive consumer complaints about un-manned displays. Our visitors pay an entrance fee and expect to be able to do business

with our exhibitors at any time during show hours. If you are in violation of this rule, your company may not be permitted to exhibit with us in the future.

**Working in the aisles or distributing brochures, etc. from any other area other than your booth is prohibited. All activity must take place inside your contracted space.**

## **DEMONSTRATIONS AND HANDOUTS**

Exhibitors demonstrating products and/or distributing marketing materials, product samples or souvenirs are not permitted to do outside the confines of their rented exhibit area. Working in the aisle is strictly prohibited and will be enforced by show management. This includes any mascots.

**ALL FOOD SAMPLING MUST BE APPROVED BY SHOW MANAGEMENT, VENUE, & HEALTH DEPARTMENT BY COMPLETING FORMS AND PAYING MANDATORY FEES.**

## **BOOTH GUIDELINES**

MPE provides each inline exhibitor with a back curtain 8 feet in height, two side curtains, each 3 feet in height and an ID sign with company name and booth number. A corner booth has only back drape. An island booth, opens on all sides, does not have any pipe and drape or ID sign.

Inline booth displays, including signage, shall not exceed 8 feet in height. Signs exceeding booth height requirements must be approved by show management or exhibitor may be asked to remove. Your display may be 8 feet high for the width of your back drape (this only applies to inline spaces). On each side you will have a 3 feet high side curtain. For inline spaces, your display may remain 8 feet in height from the back wall, up to 5 feet from the aisle, or ½ the depth of your booth. For the remaining 5 feet, your display must return to the same 3 feet height of the side curtain. **No pop-up tents allowed unless in an island booth.** All flag banners must meet sight guidelines.

All unfinished portions of displays must be draped or finished to be pleasant to the public view. Show Management may require exhibitors to purchase drape if display is not finished adequately. **Your own flooring is REQUIRED** if your exhibit space is a peninsula, special restrictions may apply as indicated by your sales representative. If Exhibitors booth is not setup by end of the move in period, show has the right to fill the space accordingly unless prior arrangements have been made with Show Manager.



*Figure 8' high x 10' wide x 3' front to back sides*

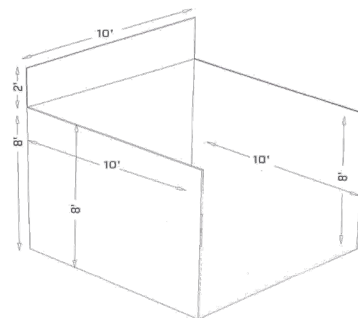

## **MICROPHONE, AUDIO EQUIPMENT & MUSIC**

Use of microphones, audio equipment and musical instruments is permitted, however, sound levels must be kept at a volume that management deems reasonable. Violators will receive one warning. If there are more problems with volume, Show Management reserves the right to prohibit the exhibitor from using sound equipment for the remainder of the show.

## **MUSIC, PHOTOGRAPHS & OTHER COPYRIGHTED MATERIALS**

Each exhibitor is responsible for obtaining all necessary licenses and permits to use music, photographs or other copyrighted material in exhibitor's booth or display. No exhibitor will be permitted to play, broadcast or have performed any music or use any other copyrighted material, such as photographs or other artistic works, without first presenting to Marketplace Events proof that the exhibitor has, or does not need, a license to use such music or copyrighted material. Marketplace Events reserves the right to remove from the exhibit all or any part of any booth or display which incorporates music, photographs or other copyrighted material and for which the exhibitor fails to produce proof that the exhibitor holds all required licenses. The exhibitor shall remain liable for all claims, causes of action, suits, damages, liability, expenses and costs, including reasonable attorney's fees, arising from or out of any violation of infringement (or claimed violation or infringement) by exhibitor, exhibitor's agent or employees of any patent, copyright or trade secret rights or privileges.

---

## **SECURITY**

Show Management provides security for the show floor during move-in, move-out, show hours and overnight. However, neither Show Management nor the Gas South Convention Center is responsible for lost, damaged or stolen articles. We encourage you to take all valuables with you when the show closes each evening. A tarp/sheet covering your booth after show hours goes a long way in securing your belongings.

Most thefts happen during move-in, move-out and within 30 minutes of show closing. Staff your booth accordingly and when the show does close, wait for the attendees to clear out.

**Report anything of a suspicious nature to Show Management and/or Security and ensure you are adequately insured.**

---

## **INSURANCE**

Show Management is insured against public liability and property damage claims arising out of the conduct of the show. This insurance does not cover exhibitors' property, which is placed on display at the exhibitor's risk. Please refer to items #4 and 5 on your exhibitor contract/application or contact Show Management if you have questions.

---

## **SHIPPING INFORMATION**

GEMS charges a drayage fee for handling any materials delivered to the convention center. Deliveries without company name and booth number will be declined. **Contact GEMS if you are sending shipments ahead of your arrival.** Marketplace Events and Gas South Convention Center are not authorized to accept your shipment. All shipments must go through GEMS, please contact them for pricing on handling shipments.

Delivery Address:

**Cannot be delivered prior to January 21, 2025**

GEMS

c/o North Atlanta Home Show

Gas South Convention Center

6400 Sugarloaf Pkwy

Duluth, GA 30097

**Company name and booth number.**



**All shipments must be prepaid and should be clearly marked with your company name, booth number and Building Name.** Special arrangements may be made with GEMS on items that need special care. Shipping items to the venue, may incur additional charges.

**Show Management is not responsible for your packages; please do not send packages before your arrival as you MUST be present to sign for them.**

Please make arrangements to dispose of or store shipping crates with the show decorator.

---

## **BUILDING REGULATIONS**

### **SMOKING/VAPING REGULATIONS**

No smoking or vaping is permitted inside any building at the facility.

### **ALCOHOL/DRUGS REGULATIONS**

No alcohol may be consumed on show site other than during designated times and locations as specified in this Exhibitor Service Manual and/or on posted signage by the show facility. Alcohol consumption is strictly forbidden during all move-in and move-out hours. Additionally, the use or distribution of illegal drugs is strictly forbidden. Any persons including exhibitors, service providers, employees, attendees or anyone else working at or attending the show that does not comply with this policy will be removed from the show and their credentials will be revoked.

### **SALE OF MERCHANDISE AT THE SHOW**

All Exhibitors are reminded that to sell products "cash and carry" during the show, you must comply with all rules and regulations of Marketplace Events. Exhibitors are responsible for obtaining any such permits as required. Only merchandise approved by the show may be sold. No food or drinks may be sold without the approval of show management and concessions.

**Local Gwinnett County Sales tax is 6%.**

### **ANIMALS/PETS**

Service animals are allowed inside the building during event hours of the event. **Personal pets are not allowed unless preauthorized by show management.**

### **FIRE REGULATIONS**

No flammable products, open flames, or flammable display materials, etc. are permitted in the exposition hall by order of the Fire Department and the Facility Security Department. **Enclosed structures under 300 sq.ft. must have a fire extinguisher and smoke detector. Enclosed structures of over 300 sq.ft. must install a sprinkler system inside the structure.** No cartons, boxes, or crates may be stored behind booth curtains. Pine straw is not allowed unless treated.

All material used in the construction and decoration of an exhibit must be flame retardant. This includes scenery, backdrops, drapes, table and dust covers.

No hazardous material will be permitted in an exhibit.

No vehicles or other apparatus, which has a fuel tank, will be permitted as a display without written permission from show management.

THE FIRE MARSHALL OF THE STATE OF GEORGIA RESERVES THE RIGHT TO MAKE ANY FINAL DECISION REGARDING THE ABOVE REQUIREMENTS.

## PARKING

There is parking available in Parking Deck 1 (Across from the Forum) for all attendees and exhibitors. Parking is \$5 can be paid via credit/debit card ONLY.

## MOVE IN AND PARKING MAP

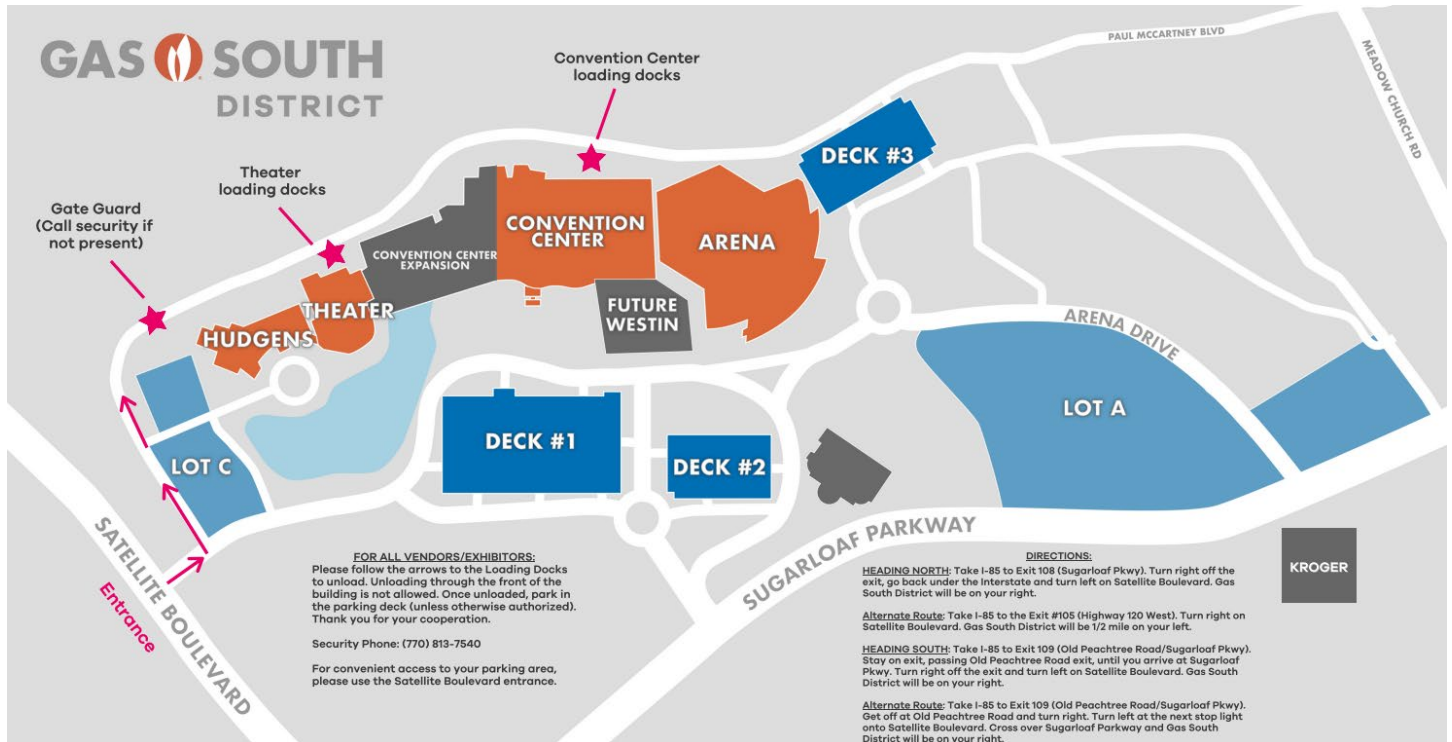

The following page has a loading/dock pass, be sure to print and bring a copy with you during move in.

North Atlanta Home Show  
BACK OF HOUSE PASS

**LOAD/UNLOAD  
PASS ONLY  
NO BOH PARKING/**

**MOVE-IN:** January 21-23

**MOVE-OUT:** January 26 5PM-10PM  
January 27 8AM – 12PM

**Cell Phone #** \_\_\_\_\_

*\*\*Please keep on dash of vehicle at all times*

PLEASE PARK IN **DECK 1** FRONT OF HOUSE  
AFTER LOADING / UNLOADING



**NORTH ATLANTA HOME SHOW  
JANUARY 24 – 26, 2025**

**ORDER FORM FOR ADDITIONAL SHOW BADGES & TICKETS**

EXHIBITOR BADGES DO NOT NEED SPECIFIC NAMES OF EMPLOYEES WORKING THE EXHIBIT. BADGES ARE FOR DAILY SHOW ADMITTANCE.

Number of Badges requested: \_\_\_\_\_ X **\$10.00**= \$ \_\_\_\_\_

Number of Tickets Requested: \_\_\_\_\_ X **\$5.00** = \$ \_\_\_\_\_

**TOTAL AMOUNT DUE: \$ \_\_\_\_\_**

Company Name \_\_\_\_\_ Booth # \_\_\_\_\_

Name on card \_\_\_\_\_

Charge My Credit Card: **VISA | MC | AMEX | DISCOVER**

Card Number \_\_\_\_\_ Exp. Date \_\_\_\_\_

Signature: \_\_\_\_\_

Phone Number: \_\_\_\_\_

Billing Zip Code: \_\_\_\_\_

**Payment by check:**

Name on check: \_\_\_\_\_ Check number: \_\_\_\_\_

Phone Number: \_\_\_\_\_

Email: [rachelw@mpeshows.com](mailto:rachelw@mpeshows.com)